



Front-end Semiconductor
equipment from the Heart of Europe



**Full Production
Horizontal
Furnaces**



**Production | R&D
Vertical
Furnaces**



**R&D
Tabletop
Furnaces**

**We are a manufacturer
of Front-end Semiconductor
equipment from the Heart of Europe.**

Our experience is based on a long history and tradition of the semiconductor industry in former Czechoslovakia, in a place called the Czech Silicon Valley.

For over 20 years we have been striving towards development of the tomorrow's tools and tomorrow's process innovations. To do this successfully, we cooperate with leading R&D laboratories, universities and scientific institutes.

The company's headquarters and production plant are located in the Czech Republic. We have world wide network of business representatives, including SVCS Service Centres in China, India, Russia and the USA.

SVCS has delivered installations for customers all over the Planet, for example: Australia, Belarus, France, China, India, Japan, Korea, Lithuania, Malaysia, Poland, Russia, Slovakia, Taiwan and the USA.

EQUIPMENT

Horizontal/Vertical Furnaces designed for all standard Atmospheric/CVD Processes suitable for Full Production.

Compact Tabletop Furnaces and Single Wafer Reactors designed as a compact solution for R&D sector like institutes or laboratories.

Ultra High Purity Gas Delivery Systems like Gas Cabinets, Valve Manifold Boxes and custom production of gas manifolds.

All SVCS tools are driven by SV-Con, our in-house designed robust control system, which can also be adjusted for refurbishments of third party equipment.

SVBro-2023_10



**UHP
Valve
Manifold Boxes**

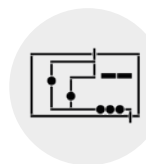

**UHP
Tailored
Gas Panels**



**Co
Sy
SV**

R&D
Tabletop
Furnaces



R&D
ALD Single Wafer
Reactors



UHP
Automatic Gas
Cabinets

**SVCS
PROCESS INNOVATION**

A circular graphic with a blue background. In the center is a white silhouette map of the Czech Republic. The word "CZECH REPUBLIC" is written in the center of the map. Above the map, the text "SVCS PROCESS INNOVATION" is written in white. Below the map, contact information and addresses are listed. The map features icons for Prague (a city skyline, a beer mug, and an airplane) and Brno (a city skyline, an airplane, and a colorful sphere).

PRAGUE

BRNO

CZECH REPUBLIC

info@svcs.com
+420 517 070 010
svcs.com

Production plant: Zámecká 133, 757 01 Valašské Meziříčí
Head office: Optátova 37, 637 00 Brno

Control
System
SV-Con



Bubbler
Precursor Temperature
Controller



EBS
External
Burn System

DESIGNED FOR HIGH PRODUCTION PERFORMANCE,
BUT STAYS EFFICIENT AND ECONOMIC.

Features and Benefits

- | Maintenance friendly mechanical design
- | State of the art modular control system, in-house designed and manufactured
- | 10,4" high-res touchscreen for operator interface
- | Up to 4 stacked quartz or SiC tube reactor chambers for various processes
- | No thermal interference between different tubes
- | Contactless fully automated boat-in-tube loading both cantilever or softlanding configurations
- | Independent tube level control system
- | HW safety interlocks independent on main CPU
- | HEPA or ULPA filters installed in load station
- | Boat elevator and wafer handling automation
- | UHP face seal fittings and welds for connections
- | UHP orbital weldings made in 100/10 Cleanroom



Full Production

Technical Data

Sample dimensions W x D x H (mm)	5600 x 2600 x 1000
Wafer size (mm)	150, 200, 300 or any custom size
Wafer load	100+
Heating system	3 or 5 zone
Flat zone	Up to 1067 mm (42")
Process temperature	200°C to 1300°C, ± 0.5°C across flat zone
Power consumption	18kW - 30kW per tube
Power supply (adapted to power grid of destination country)	150 mm: 3-phase, 400 or 480VAC, 140A, 50 or 60Hz 200 mm: 3-phase, 400 or 480VAC, 160A, 50 or 60Hz
Clean dry air	70 – 110 psig (4,8 to 7,6 bar)
Cooling water	40 – 60 LPM
Exhaust	210m ³ /h per tube
Options	Boat elevator and wafer handling automation

SVFur-FPx



Processes

Atmospheric

- | Diffusion (drive-in) high temperature processes
- | Doping from solid, liquid and gaseous dopant sources e.g. BBr_3 , B_2H_6 , $POCl_3$, PH_3 , BN
- | Various thermal processing e.g. annealing, sintering
- | Pyrogenic wet Oxide with EBS
- | Wet Oxide with ultra pure steamer
- | Dry Oxide
- | HiPOx (High Pressure Oxide)

LPCVD

- | Silicon nitride
- | Low temperature oxide (LTO)
- | High temperature oxide (HTO)
- | TEOS oxide
- | Polysilicon, with tilt/flat temperature profile
- | Doped polysilicon
- | Oxynitride

PECVD

- | Silicon nitride (incl. anti-reflective SiN solar cell coating)
- | Silicon oxide
- | Oxinitride

DCE or HCl optional for all processes

Furnaces

Wafer Handling Automation for easy operation



Partial automation

- | Stand-alone cassette to boat wafer transfer system

Full automation

- | Boat elevator
- | Fully automated stocker with built-in elevator and wafer transfer system

Typical configuration for Boat Elevator is 5 boats each with 50 slots each (200 mm wafers) and 6 boats (150 mm wafers).

In case of stocker, the system includes built-in wafer handling robot and the boat elevator. The stocker is integrated into the horizontal furnace and stores loaded and unloaded cassettes for a smooth continuous and fully automatic furnace operation.

CONFIGURABLE FOR FULL PRODUCTION OR R&D APPLICATIONS

SVCS Vertical Thermal Reactor (VTR) is designed for all standard Atmospheric and Low Pressure CVD Processes. VTR is available with several lengths of flat zone for both Mass Production and R&D Application. The Single Tube Set-Up with Dual Boat Logistics is optimized for minimum downtime as well as low maintenance costs.

Features and Benefits

- | Automatic wafer handling system for loading wafers from SMIF or FOUP closed pods
- | Special automatic loading system which allows loading wafers from open cassettes and provides an exceptionally small footprint
- | Quartz or SiC boats can be used
- | Highly tailored state of the art modular control system, in house designed and manufactured
- | 10,4" high-res touchscreen for operator interface



Production | R&D

Technical Data

Wafer size (mm)	100, 150, 200, 300 or any custom size
Wafer load	25 – 150 wafers/batch
Heating system	3 or 5 zone
Flat zone	Up to 600 mm (24")
Process temperature	200°C to 1230°C, ± 0.5 °C across flat zone

Processes

Atmospheric

- | Diffusion (drive-in) high temperature processes
- | Doping from solid, liquid and gaseous dopant sources e.g. BBr₃, B₂H₆, POCL₃, PH₃, BN
- | Dry Oxide
- | Pyrogenic Wet Oxide with External Burning System
- | Various thermal processing e.g. annealing, sintering

LPCVD

- | Silicon nitride / low stress nitride
- | Oxynitride
- | High temperature oxide (HTO)
- | Low temperature oxide (LTO)
- | Polysilicon, both with tilt and flat temperature profile
- | Doped polysilicon
- | TEOS oxide

DCE or HCl optional for all processes

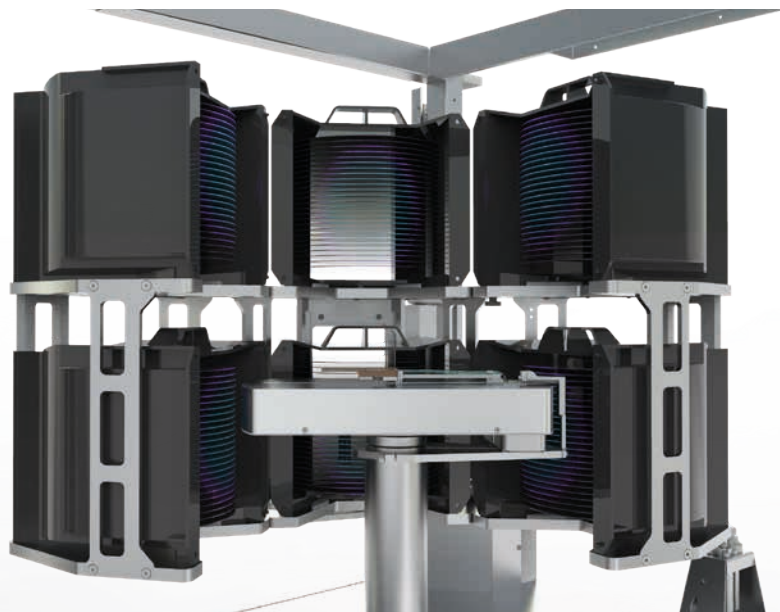

Vertical Furnaces

Power consumption	22kW - 30kW
Power supply (adapted to power grid of destination country)	3-phase, 400 or 480VAC, 40 – 100A, 50 or 60Hz
Clean dry air	70 – 110 psig (4,8 to 7,6 bar)
Cooling water	10 – 15 LPM
Exhaust	170m ³ /h

UNIQUE COMPACT DESIGN, ALL FEATURES OF THE GROWN-UP FURNACE

Features and Benefits

- | Ideally suited for R&D labs and pilot fabs
- | Small footprint
- | Table or standalone solution (with stands)
- | Stackable desing (e.g. double tabletop variant)
- | Low power consumption
- | Easy operation and maintenance
- | Heating element with 1 or 3 temperature zones and max. temperature up to 1300 °C
- | Modern modular proprietary control system
- | Up to 8 gas lines and 2 liquid sources
- | Independent hardware safety interlocks
- | Integration of vacuum pump systems in cooperation with leading pump manufacturers

The SVCS Tabletop Furnace system provides a semiconductor grade quality tool for universities, R&D laboratories and pilot fabs. This system can be used for wide range of processes due to outstanding flexibility and amount of optional modules available to meet special and often unique requirements of every customer.



R&D

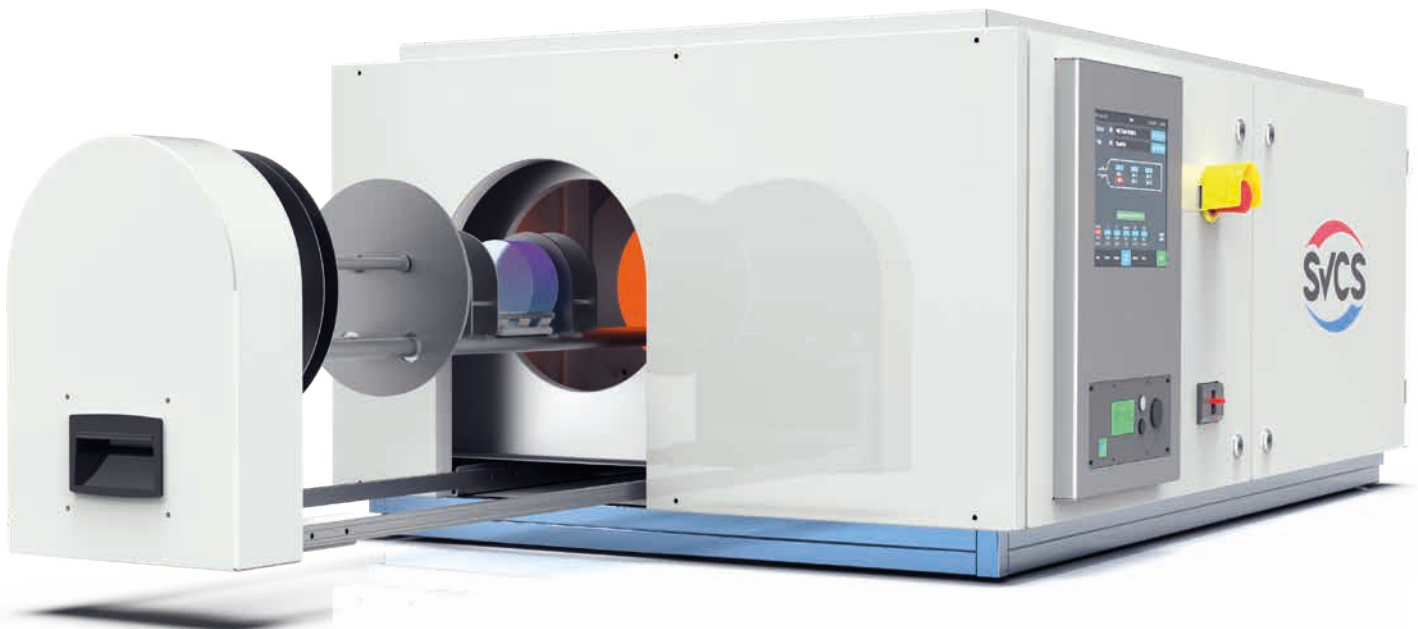



Processes

Atmospheric

- | Diffusion (drive-in) high temperature processes
- | Doping from solid, liquid and gaseous dopant sources e.g. BBr₃, B₂H₆, POCL₃, PH₃, BN
- | Various thermal processing e.g. annealing, curing, sintering
- | Pyrogenic Wet Oxide with External Burning System
- | Wet Oxide with ultra pure steamer
- | Dry Oxide
- | HiPOx (High Pressure Oxide)

LPCVD

- | Silicon nitride
- | Low temperature oxide (LTO)
- | High temperature oxide (HTO)
- | TEOS oxide
- | Polysilicon, both with tilt and flat temperature profile
- | Doped polysilicon
- | Oxynitride

PECVD

- | Silicon nitride (including anti-reflective SiN solar cell coating)
- | Silicon oxide
- | Oxinitride

DCE or HCl optional for all processes

Compact Tabletop Furnaces

Technical Data

Weight	350kg
Sample dimensions W x D x H (mm)	1900 x 1100 x 600 (Depending on configuration)
Wafer size (mm)	50, 75, 100, 150, 200
Wafer load	5 - 50 wafers
Heating system	1 or 3 zones
Flat zone	Up to 600 mm (24")
Process temperature	200°C to 1230°C, ± 0.5°C across flat zone
Power consumption	17kW
Power supply (adapted to power grid of destination country)	3-phase, 400 or 480VAC, 40 - 100A, 50 or 60Hz
Clean dry air	70 – 110 psig (4,8 to 7,6 bar)
Cooling water	10 – 15 LPM
Exhaust	100m ³ /h

ALD REACTOR WITH COMBINED MW SURFATRON AND ECWR PLASMA SOURCE

Features and Benefits

- | Thermal and plasma ALD with process temperature up to 400°C
- | Thin film depositions on various wafers sizes
- | Height adjustable electrically isolated substrate holder (variable distance from the plasma discharge)
- | Substrate rotation up to 60rpm
- | Solid state MW and RF power generators (300 and 1200W)
- | Load-lock Automation
- | Clean-room ready
- | Connecting various equipment for in-situ process monitoring (ellipsometry, mass spectroscopy, ...)
- | Atomic Layer Etching option with tunable substrate biasing

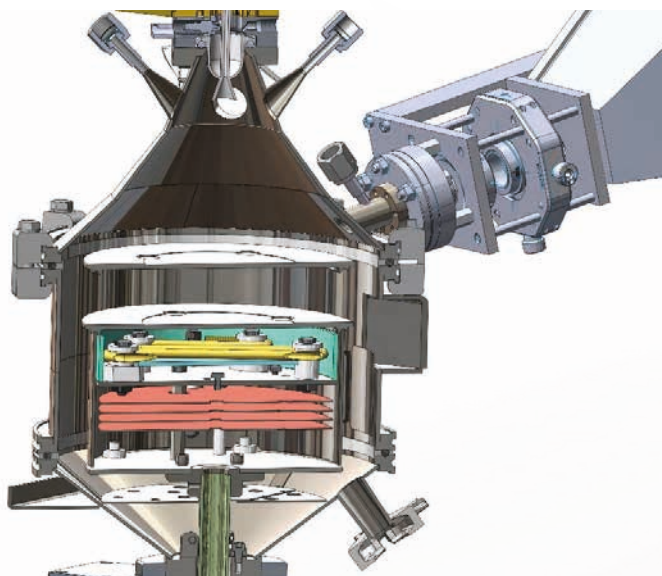

R&D

Technical Data

Process temperature	up to 400°C
Wafer size	up to 300 mm
Dimensions of the Box W x H x D (mm)	2000 x 1700 x 650 (Depending on configuration)
Weight	300kg
Max. power consumption	4,5kW (incl. 1,8kW of pumping system)

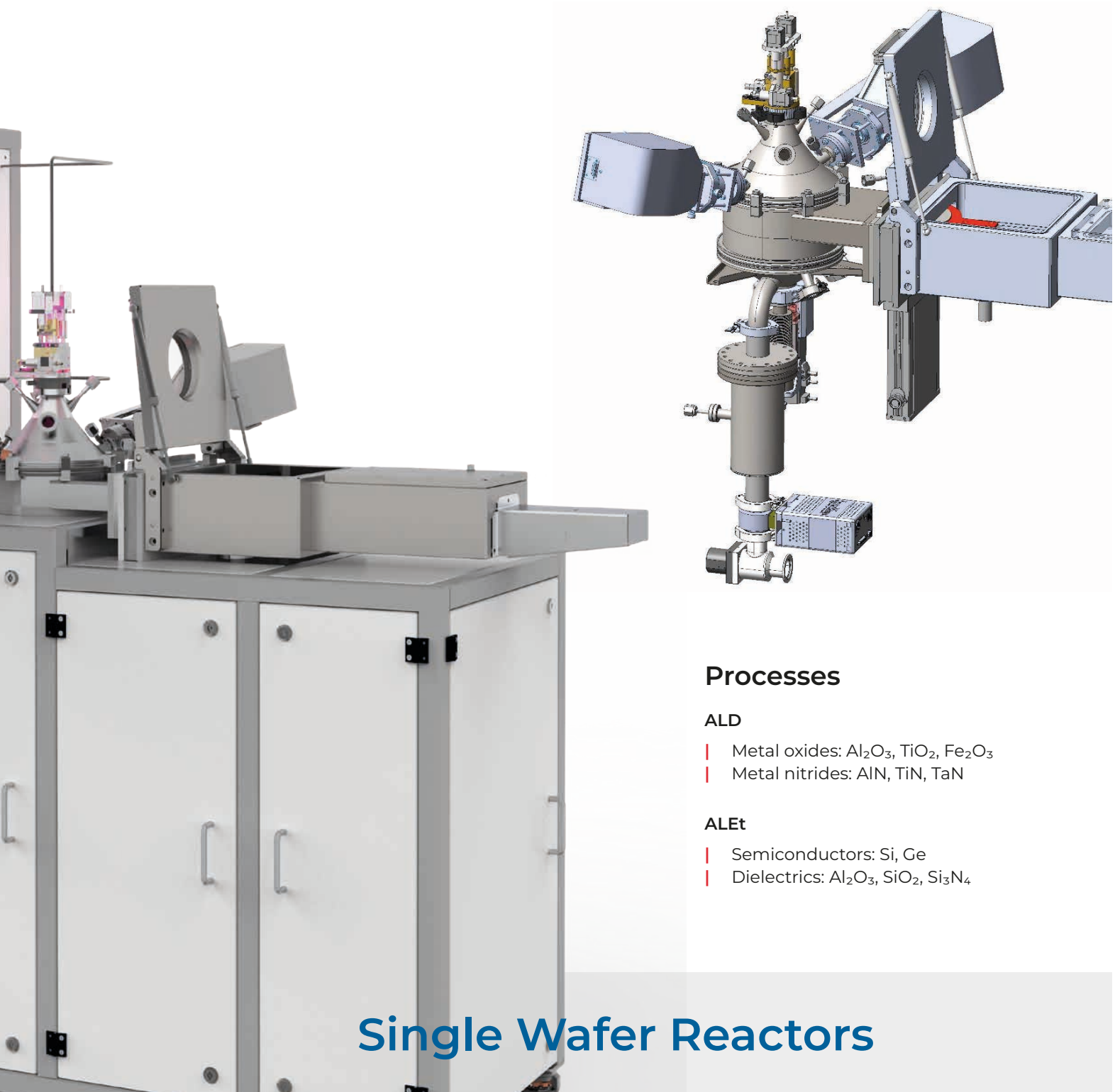

Processes

ALD

- | Metal oxides: Al_2O_3 , TiO_2 , Fe_2O_3
- | Metal nitrides: AlN , TiN , TaN

ALEt

- | Semiconductors: Si , Ge
- | Dielectrics: Al_2O_3 , SiO_2 , Si_3N_4

Single Wafer Reactors

Within international R&D project we developed together with ISAC Research (Korea) this unique reactor including the ALD gas panel for metal oxide and metal nitride thin film depositions on wafers with sizes up to 300 mm. Thus, we are not limited by standard wafer sizes, we can make substrate holder for any type of wafer. Perfect solution for R&D laboratories and Institutes. For example – we can make it for batch deposition on five 100 mm wafers, etc.

ALD reactor and load-lock chamber are designed as double-table solution for possible installation of load-lock chamber in clean rooms.

TAILORED GAS SYSTEMS AND GAS PANELS FOR VARIOUS WAFER PRODUCTION TECHNOLOGIES

SVCS takes advantage of many years of experience in manufacturing tailored gas panels and gas systems for various wafer production technologies, as well as various R&D customized panels. SV-DELI gas delivery system family offers a high level of technical design, components from the world leaders and a fully automatic control system with independent safety functions.



Ultra High Purity

Features and Benefits

- | Fully automatic control system with Touchscreen display
- | Automatic cycle purging
- | Cylinder pressure or cylinder weight monitoring
- | Pressure transducer for output pressure monitoring

- | Excess flow switch
- | Programmable cylinder pressure or weight limits for auto changeover
- | External digital inputs and outputs
- | Multiple level password protection for various operation modes
- | Ethernet interface for LAN connection

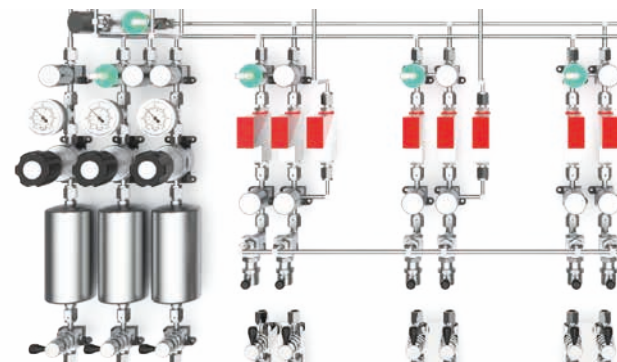

AGC | VMB | Gas Panels



AGC Automatic Gas Cabinets

- | Open, wall mounted systems (for inert gases)
- | 1-cylinder cabinet, with purge gas from external source
- | 2-cylinder cabinet
 - | 2 process gas cylinders, w/purge gas from ext. source + auto changeover
 - | 1 process gas cylinder, 1 purge gas cylinder
- | 3-cylinder cabinet (2 × process + 1 × purge), with auto changeover

VMB Valve Manifold Boxes

- | 2 typical modifications: 2-4 and 5-8 independent outputs
- | A wide range of automation: from manual control to fully automatic
- | Optional connection to the integrated control system SVCS Super Visor
- | Process gas leak detection
- | Hazardous gases detection and ventilating the space of gas panels

Gas Panels

- | Orbital welded, manufactured and assembled in 10/100 Cleanroom
- | 100 % Helium leak test and functional test of all individual components before/after welding and panel assembly
- | Tubing, fittings, valves, pressure regulators, filters, flow devices and MFCs with either metal face or butt weld connections
- | Surface roughness Ra max. 10 µinch or better
- | Very low internal volume achieved by using special mini-weld heads
- | Compact internal vacuum generator for cycle purging

Gas Delivery Systems

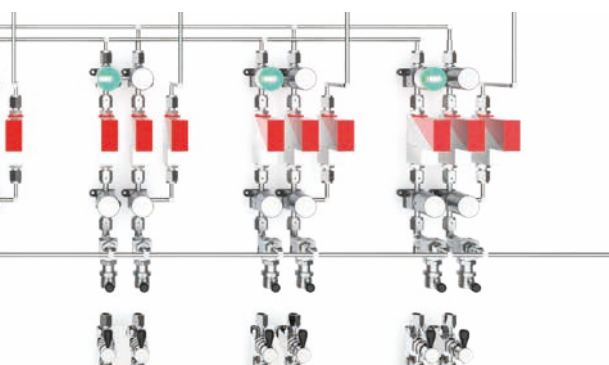

Optional

- | Tailored gas panel according to specific customer request
- | Pigtail purging manifold ("deep-purge")
- | Monitoring of dangerous gas presence
- | Pressure monitoring in the coaxial tubing outer containment
- | Additional particle filtering and/or purifying of process and purge gas
- | Analytical testing services and certification for particles, moisture, oxygen and total hydrocarbons

SV-Con Control System

SV-Con is a set of HW, SW and I/O interfacing. It's development was supported by EU fundings and consulted by university and industry experts. System is fully modular and can be configured for horizontal/vertical thermal reactors, as well as other equipments used in semiconductor industry. SV-Con is ready both for installation in the new SVCS's furnaces (SV-Fur and SV-Sol) and in other manufacturer's refurbished equipment.

System Features

- | Fully modular
- | Powerful CPU unit
- | 10,4" touchscreen LCD for operator interface
- | Robust and reliable Linux OS for control apps
- | TCP/IP based network
- | Remote access

SW Features

- | Windows based SW for operating personnel
- | Real-time monitoring
- | Process recipe management
- | Graphs (temperature, gas flow, ...)
- | Event log (alarms, aborts, recipe progress, ...)
- | Intelligent cascade temp. regulator with accuracy 0.1°C



System

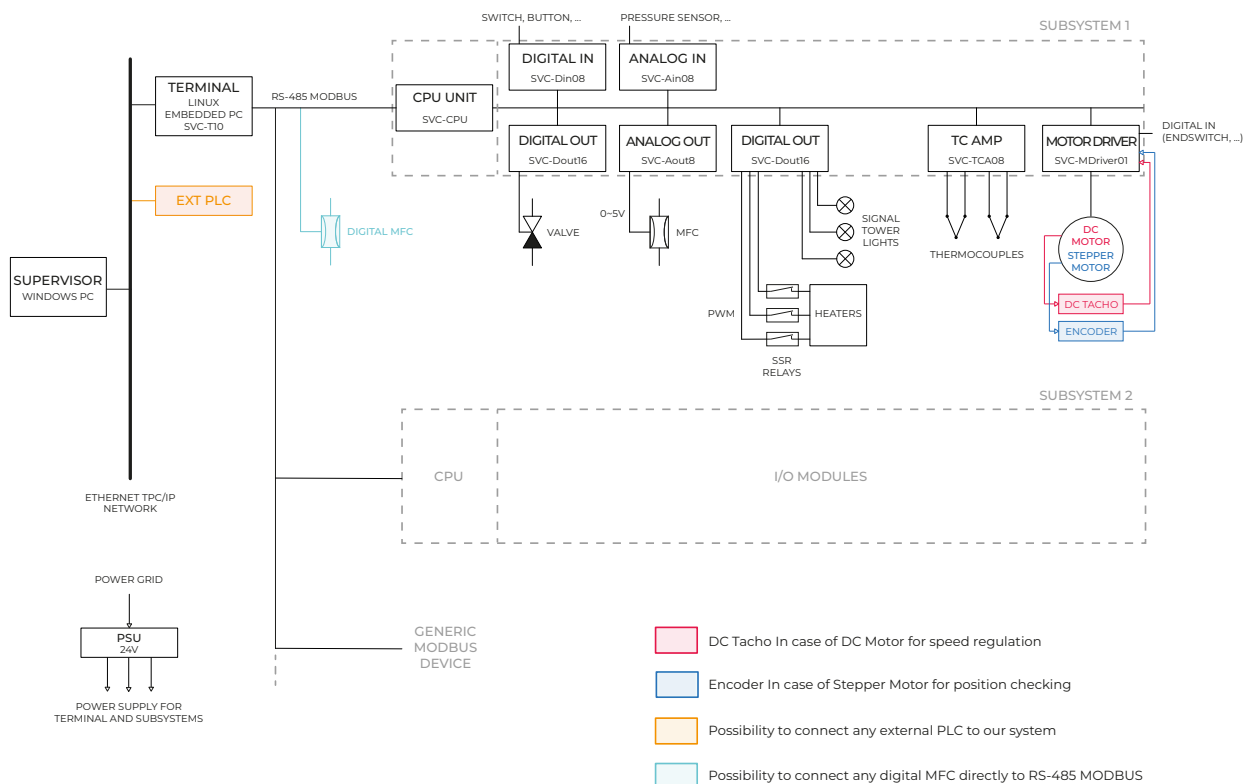

SV-Con | Bubbler | EBS

Bubbler Precursor Temperature Controller



Many reaction constituents for semiconductor and PV processes are available only in liquid phase. We adopted suitable delivery systems to make them usable for technology process. One of the methods is based on liquid vapor pick-up by flowing gaseous media through the liquid. Flow of such carrier gas is controlled by electronic MFCs and is introduced to liquid container through a dip-tube while a carrier vapor mixture leaves the container through separate top outlet. In order to maintain the same pick-up rate during the whole process and from process to process, liquid media temperature has to be precisely controlled. We developed proprietary powerful combined cooling/heating engine for dry bath environment.

Technical Data

Dimensions W x H x D (mm)	320 x 240 x 320 (Liquid container Ø 145 - 155)
Weight	15kg
Max. power consumption	150W (Cooling power 30W)
Max. cooling/heating, relative to ambient	-20°C/+50°C
Regulation accuracy	+/-0.1°C

Components

EBS External Burn System

The EBS (Ex-Torch) is a diffusion furnace accessory used for pyrogenic oxidation processes. It generates high purity water vapor by burning Hydrogen in Oxygen. This burning is made in an external quartz chamber so the process tube working zone is not affected by hydrogen flame. Heating to Hydrogen self ignition temperature is achieved with electrical resistance heater.

Though this way of heating is not the fastest one, its robustness and durability pays off the inconvenience to start with heating a bit earlier in the process recipe.



Technical Data

Dimensions W x H x D (mm)	135 x 130 x 270
Weight	3,5 kg
Supply Voltage	230V, 4,5A, 50Hz
Service Temperature Range	0 – 50°C

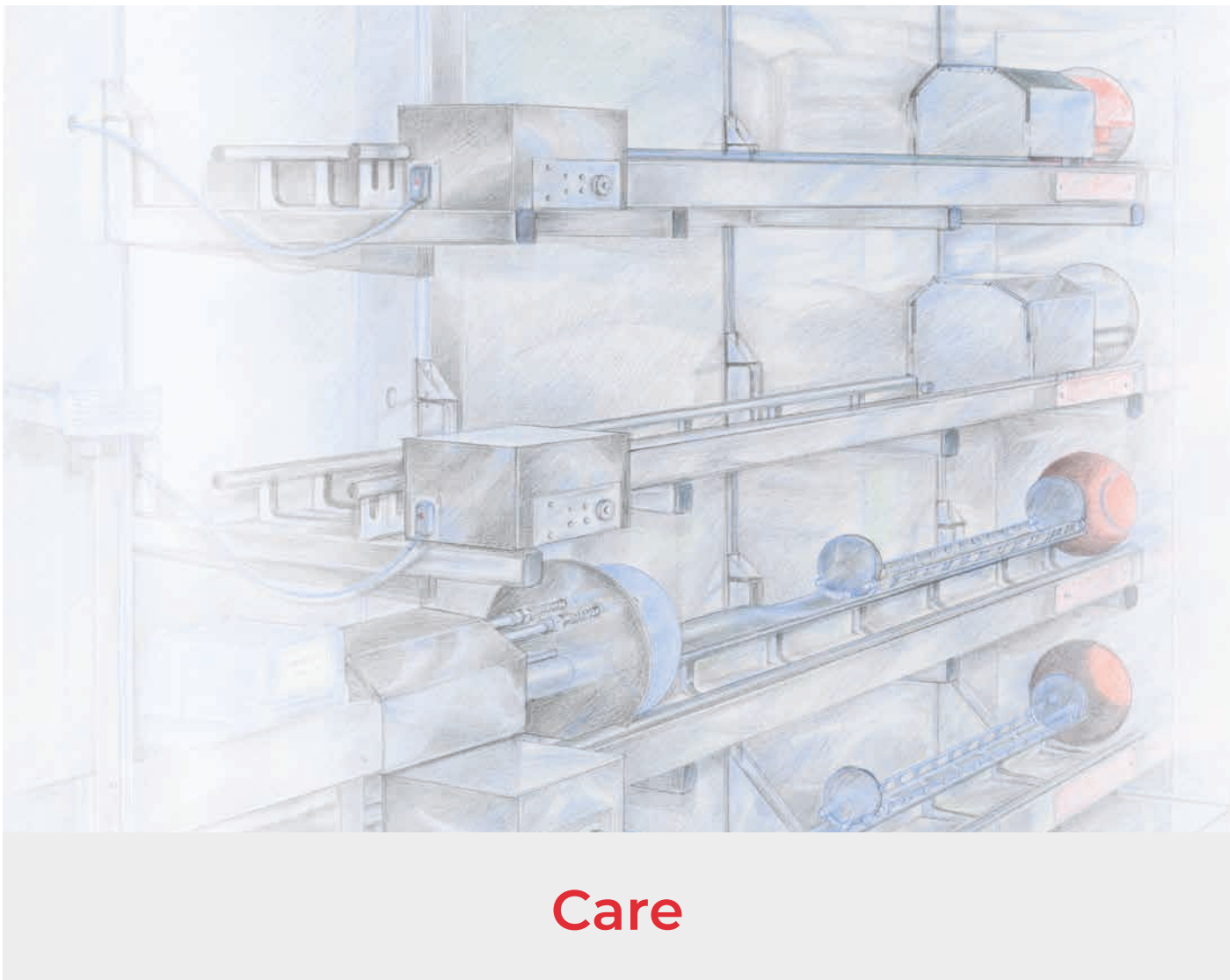

Care

Accredited calibration laboratory and MFC service center

The laboratory is equipped with ultrasound cleaning line and helium leak detector. It has controlled environment monitored by recording system. The typical scope of instruments calibrated and serviced include electronic mass flow meters (analog/digital), together with mass flow controllers (MFC), both analog and digital. The calibration can be provided for any commonly used MFCs on the market.

Remote and On-Site care

We provide remote and on site post warranty care for all our equipment through our experienced team of field engineers together with trained technicians of our representatives where available. We can offer regular on site repair and maintenance on the basis Annual Maintenance Contract. To keep the technology up to date we can also make various systems retrofits and modernisation for existing equipment on site.

Cooperation with universities and scientific institutes

Cooperation with a number of renowned universities as well as research and scientific institutes around the world on research and development of advanced dedicated equipment for specific processes.



TRADITIONS MEET TECHNOLOGIES

Cooperation



UNIVERSITY
OF WEST
BOHEMIA



FZU
Institute of Physics
of the Czech
Academy of Sciences



CEITEC
central european institute of technology
BRNO | CZECH REPUBLIC



Vilnius
University



Zelenograd
nanotechnology
center



INME RAS
Institute of Nanotechnology of Microelectronics
of the Russian Academy of Sciences



上海交通大学
Shanghai Jiao Tong University



Indian Institute of Technology Madras
भारतीय प्रौद्योगिकी संस्थान मद्रास



2015

CZE-KOR R&D
Project: Plasma
ALD Reactor



2016

R&D/Production
Furnaces
goes to Russia



2017

Vertical Furnaces
for production
and R&D



2018

SVCS
proc...
to Fr...



2013

SVCS technology
arrived to Antipodeans
in Australia



2012

Building
brand-new
factory



2011

R&D Furnaces
goes to India
market



2010

Our R...
Furn...
to Ma...



2018

SVCS supplies process equipment to France



2019

CZE-JPN R&D Project: ALD Reactor for Minimal Fab



20 YEARS of experience and innovation



2034

The Planet of the SVCS Equipment



2009

Our Horizontal Furnaces goes to Malaysia



2007

Taiwanese students trained on SVCS Furnaces



2005

Diffusion Furnaces for Chinese customers



2000

SVCS founded in the Czech Silicon Valley

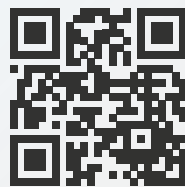

svcs.com



Co-funded by
the European Union



MINISTRY OF INDUSTRY AND TRADE
OF THE CZECH REPUBLIC